

## DIESEL EXHAUST FLUID DISPENSER FILTERS

### CT41070 AdBlue Filter Housing 1"BSPP

Cim-Tek® Filtration understands that diesel exhaust fluid (AdBlue) is a key ingredient for allowing the selective catalytic reduction (SCR) system to reduce emission pollutants such as NOx (nitrogen oxides). In response to the new 2010 truck regulations for SCR systems, we have developed AdBlue® filters for particulate and crystal removal from AdBlue fluid at the dispenser to ensure SCR systems function properly.

- Filter removes particulates & crystals from AdBlue fluid
- Particulate-Free AdBlue will not plug dosing valve
- Ultra-Clean AdBlue fluid is critical in making the SCR systems on the truck function properly
- All Materials Compatible with AdBlue
- Flow Rate: 76 L/min.
- Maximum Pressure: 10,3 Bar.
- This Filter Housing can be used with Gravity Tanks, but the flow would be very low (slow), because the restriction of the media (5 micron).

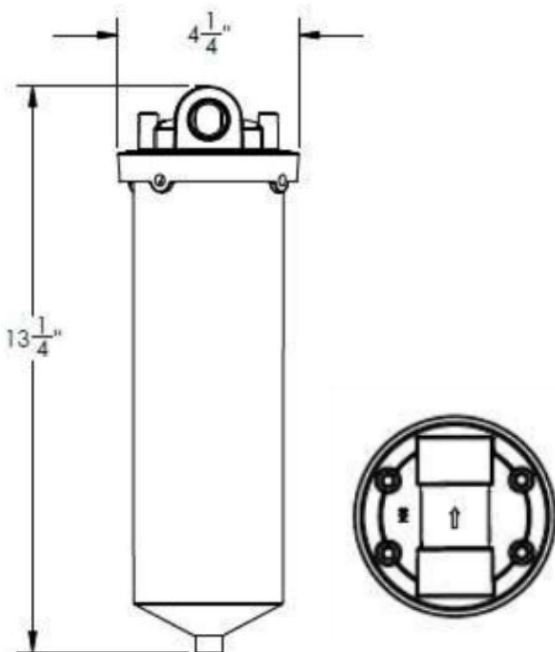

Element  
5 micron  
CT31015

Heavy Duty Housing  
Stainless Steel (304)  
Head 1" NPT  
Inlet/Outlet